

# Power Consumption of IoT Access Network Technologies

Chrispin Gray, Robert Ayre, Kerry Hinton, Rodney S. Tucker

Centre for Energy-Efficient Telecommunications

University of Melbourne, Melbourne, Australia

Email: cgray@student.unimelb.edu.au; (rayre; k.hinton; r.tucker)@unimelb.edu.au

**Abstract**—Over the past couple of years, many commentators have hailed the “Internet of Things” (IoT) as the next step in the evolution of the internet. This paper examines, from an energy consumption viewpoint, some options for deploying a network of “Things” and connecting them through their gateway into the Internet or a corporate network. It focuses specifically on the access network from the customer premises to the central office and the implications for this network of carrying uplink-dominant IoT traffic. The power consumption of a number of potential access network technologies and architectures is modelled for a range of IoT traffic and background network traffic levels. It is shown that shared corporate Wi-Fi network with PON backhaul can be the most energy efficient option if the Wi-Fi background traffic level is modest. Otherwise, a 4G Wireless (LTE) access is also very efficient if the site IoT traffic level is low – up to around 100 kb/s. At higher rates a GPON access provides the most energy efficient solution.

**Keywords**—power consumption; internet of things; access network technologies; power efficient; energy efficiency;

## I. INTRODUCTION

Many commentators have argued that the so-called “Internet of Things (IoT)” is a major new paradigm that will have a large social and economic impact. In essence, the IoT involves the use of devices, connected over the Internet to measure, report, and in some cases perform actions autonomously. It is estimated that the IoT will host between 50-200 billion connected devices by the end of the decade [1, 2]. This explosion of connected devices may lead to network traffic growth, and the energy cost of additional network equipment needed to support that growth is unknown.

Devices in the IoT can take many forms, and potentially be accessible from anywhere by anyone [3]. Although many of these devices may be embedded sensors, actuators or RFID tags, which are mostly low-powered, they also require a gateway device and an access network which may not be energy-efficient [4]. Many of the “devices” in the IoT will be sensors, for example reporting periodically on their environment, sending small data packets at regular intervals, with a low aggregate traffic level. However some of the “devices” may be video cameras, sending data continuously, for which the traffic requirements will be substantial.

The power consumption of the ICT industry is of importance as it is estimated to account for 2-4 % of worldwide carbon emissions [5]. Access networks provide the initial points of connection between IoT devices and the Internet or the

Cloud, and several studies [4-6] indicate that the access network is the least energy-efficient part of the Internet. One study has quantified the energy consumption of different fiber access technologies [7], up to their maximum theoretical data rate while another considered a mixture of copper and fiber access networks [8]. In [4], wireless access technologies were found to be the least energy-efficient of the access network technologies but for downlink data rates above 1 Mbit/s. It is therefore important to note that different access technologies provide different per-user bandwidth levels, and have dissimilar power usage. However, IoT installations may involve low aggregate traffic volume (mostly uplink) per connected device, but far greater numbers of connected devices [9]. Furthermore, many IoT use-cases (e.g. Smart Agriculture, Environmental Monitoring) will be deployed remotely from established home or office networks. Hence the choice of access network technology for lower bandwidth requirements becomes relevant.

In this paper, we consider a number of access network technologies and architectures that are appropriate to IoT applications and identify some of the more power-efficient access technologies for the IoT over a range of traffic levels. We evaluate current wired and wireless network architectures, using a range of data sources; equipment manufacturers’ datasheets, some measurements and previous literature. We compare the power consumption and energy-efficiency of the various technologies for low bit rates (sub-1 Mb/s). In this work, we do not specifically distinguish between device data traffic and the required protocol and signaling overheads, which can be substantial for small-packet data flows. We conclude with suggestions on power-efficient access network choices for future IoT installations. The rest of the paper is organized as follows: Section II describes the IoT access network architectures considered while section III puts forward a power consumption model. Section IV discusses the treatment of energy consumption as shared and unshared network elements and section V describes the power consumption estimation for each node. Section VI gives the results and section VII concludes the paper.

## II. IOT ACCESS NETWORK ARCHITECTURE

Fig. 1 illustrates a range of access network options for connecting an IoT gateway device, which aggregates traffic from a number of individual sensors with short-range interfaces, through to the Internet core. It is assumed that the access network carrying IoT traffic would be broadly the same

or similar to today's access network, but handling different traffic loads. Hence we consider the energy consumption of different access network types when handling traffic with IoT-like statistics. This range of network architectures, are representative of the network access technologies that may be used in future IoT deployments. An IoT access network thus consists of four main nodes: the IoT gateway, the customer premises equipment (CPE) modem, the remote network node and the edge/central office node located at the central office.

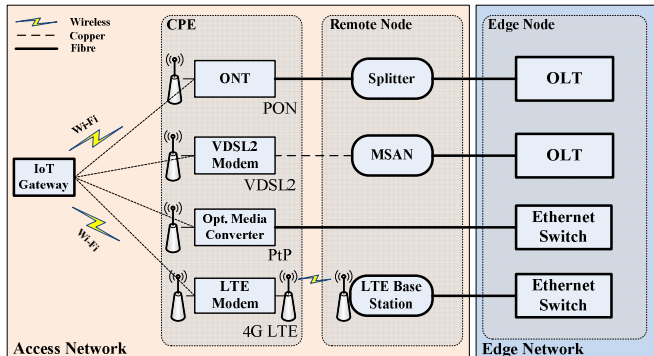

Fig. 1: Schematic diagram of an IoT access network

The range of access network technologies considered here includes the following:

A Passive Optical Network (PON), in which a cluster of customer sites share a connection to a network Optical Line Terminal (OLT) at the parent exchange or central office via a passive splitter; commonly the split ratio is 32- or even 64-way, but the split ratio depends on the planned traffic level.

A VDSL2 (Very-high-bit-rate Digital Subscriber Line) network in which customer sites connect via existing copper pairs to a nearby concentrating network element. This may be described as a DSLAM (Digital Subscriber Line Access Multiplexer) or MSAN (Multi Service Access Node). This node connects via optical fibre to its parent exchange. With VDSL2, access rates up to 100 Mb/s (symmetric) can be achieved [10].

An optical Point-to-Point link provides a dedicated fibre connection from the customer site to the central office. Such systems are more commonly used where customer traffic demands are high, e.g. an office complex, hospital, or school.

Wireless access using the 4G LTE [11] cellular network. The customer site modem connects to a local cellular base station, which in turn connects back to a switch at the central office, typically via fibre. The traffic capacity of LTE depends on the transmission path in terms of distance, topography, and interference from other signals, and is generally lower than the theoretical figures quoted.

Wi-Fi which is a short-range wireless technology suited to cable-free connecting of user devices to the site CPE modem. It may be useful in providing connectivity between the IoT gateway and the network-facing modem, and in some instances between the sensors or "things" and their gateway.

In addition to the traditional access technologies described above, an IoT access network brings an additional network segment to the architecture. We choose to call this segment an

IoT network (IN) as it includes a myriad of low-powered sensor and actuator devices, communicating through an additional aggregating network element, known in this study as the IoT gateway. An IoT network typically includes a wireless network or personal area network (PAN) connecting each sensor or actuator device to its parent gateway. Many protocols, including Bluetooth, ZigBee and Wi-Fi are expected to be employed in this network segment [9].

### III. POWER CONSUMPTION MODEL

The IoT access network includes the IoT gateway device in addition to the CPE modem, the remote node (RN) and the edge node (EN). The IoT gateway aggregates data traffic from the IN devices en-route to the public network. The total network power consumption per IoT gateway can be expressed as:

$$P = P_{IoT} + P_{CPE} + 1.5(P_{RN} + P_{EN}) \quad (1)$$

where  $P_{IoT}$ ,  $P_{CPE}$ ,  $P_{RN}$  and  $P_{EN}$  are the power consumption of the IoT gateway device, the CPE modem, the remote node and the edge node respectively. The multiplier value of 1.5 is used as a representative value to account for overheads from the use of cooling and uninterruptable power systems at network sites (akin to the power usage effectiveness, PUE factor in data centres). The IoT gateway is independent of the access network technologies, and connects to the public network via the CPE modem using either an Ethernet port or Wi-Fi access. We have considered data access rates between 1 kb/s and 1 Mb/s.

Power consumption values reported in manufacturers' datasheets for commercial access network equipment, together with some measurements (where applicable) are used in our analysis. We acknowledge that different access technologies provide different data rates, which may also be dependent on the distance of the installation from the network edge node. In order to achieve a level of fairness in our analysis, we employ practical, achievable data rates that are based on field reports and datasheets.

### IV. SHARED AND UNSHARED NETWORK DEVICES

In this section, we describe the modelling of each network element in the IoT access network. To fairly represent the different usage characteristics of networking devices, they are classified into two main types: (i) an unshared network device; (ii) a shared network device. Based on measurements [12], the power consumption of network elements are modelled as slightly load-dependent as shown in Fig. 2. In the figure,  $P(C)$  represents the power consumption of a network device with a traffic load  $C$  in bits per second.  $P(C)$  can therefore be expressed as  $P(C) = P_{idle} + E_b C$ , where  $P_{idle}$  is its no-load power consumption and  $E_b$ , its incremental energy per bit, given by the slope of the graph.

#### A. Unshared Network Device

An unshared network device refers to network equipment that is dedicated to a single or few users (e.g. CPE modem). This would include an access modem for xDSL services, a PON customer's optical network terminal, and "home" Wi-Fi (but not shared or corporate Wi-Fi) router. Using a power-based model for single-user equipment [13], the power consumption of an unshared network device at load  $C$  is given as:

$$P(C)_{unshared} = P_{idle} + \frac{P_{max} - P_{idle}}{C_{max}} C \quad (2)$$

where  $P_{max}$  is the equipment power consumption at maximum load  $C_{max}$ . Incremental energy per bit for an unshared network element  $e_{bit}$  is expressed as  $(P_{max} - P_{idle})/C_{max}$ ; hence  $P(C) = P_{idle} + C \cdot e_{bit}$ . The difference however (i.e. between  $P_{idle}$  and  $P_{max}$ ) is usually quite small;  $P_{idle}$  can be as high as 90% of  $P_{max}$  [12] in high capacity equipment. Therefore, the product  $C \cdot e_{bit}$  is insignificant for small values of  $C$  ( $< 1$  Mb/s), hence we accept typical power consumption values from datasheet as a representative power value for the total data throughput range.

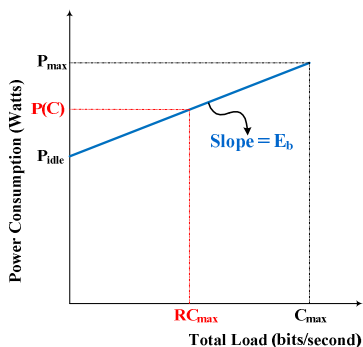

Fig. 2: Power Consumption of a generic network element

### B. Shared Network Devices

A shared network device refers to a heavily utilized network element that is shared by many (hundreds / tens of thousands) users, applications and services at the same time. Network administrators mitigate possible congestion or bottlenecks in the network by monitoring and maintaining a network equipment utilization  $R$  (a percentage of  $C_{max}$ ) such that  $0 < R < 1$ . Hence the background traffic level of a shared network device at any time of day  $C_{bgd}$  is modelled as  $C_{bgd} = RC_{max}$ . For a shared access network node carrying IoT traffic as an addition to its background traffic, the total power consumption of the node  $P_{shared}$  can be expressed as:

$$P(C)_{shared} = P_{idle} + \frac{P_{max} - P_{idle}}{C_{max}} \times (C_{bgd} + C_{IoT}) \quad (3)$$

where  $C_{IoT}$  represents a segment of total traffic through a shared network access device that is generated by IoT devices at the edge of the network. We wish to allocate part of the equipment idle power to each traffic component according to its volume, plus an allocation of the incremental power usage based on the  $E_b$  as shown in Fig. 2. We use  $E_{BIT}$  as a convenient metric that allows us to add the energy used by individual data streams as they pass through a number of network elements. The overall network element energy-per-bit can hence be expressed as:

$$E_{BIT} = \frac{P(C)_{shared}}{C_{bgd} + C_{IoT}} = \frac{P_{idle}}{C_{bgd} + C_{IoT}} + \frac{P_{max} - P_{idle}}{C_{max}} \quad (4)$$

Traditionally, the access networks are designed to handle traffic in which downstream volumes dominate, or at most traffic is symmetrical. IoT traffic instead typically involves the

generation of a large number of small packets, with upstream traffic dominating the flow. Our measurements of the open-source ninja block home automation system [14] indicate an approximate uplink-downlink ratio of five to one (5:1) when few sensors are connected to the block, and a ratio of about 23:1 for an image streaming IoT application. This observed variation departs from customary internet applications that are downlink intensive (e.g. browsing, video-on-demand). Its importance can be critical in network devices with unequal uplink and downlink power budget (e.g. cellular network base station). We have excluded image/video streaming in the present study and therefore assume a 5:1 ratio of uplink to downlink bit-streams. If the background traffic is far greater than the IoT traffic for a specific network node (i.e.  $C_{bgd} \gg \gg C_{IoT}$ ), we express the incremental power consumption of the network element attributed to the IoT traffic as:

$$P(C)_{inc-shared} = E_{BIT} B \quad (5)$$

where  $B$  is the access bitrate of IoT gateway in bits per second.

### V. ESTIMATING POWER CONSUMPTION OF ACCESS NODES

In this section we estimate the power consumption of the above network architectures. Table 1 lists the key network elements considered with their corresponding numbers of users or ports, maximum upstream and downstream data rates and power consumption values.

#### A. IoT Network

Emerging IoT and M2M applications (e.g. SmartThings, Phillips Hue, and Ninja Block) generally set up an IN. One factor that is common amongst many such applications is the requirement for an IoT gateway/hub, which acts as an aggregation device between the end devices (e.g. sensors, light bulbs) and the Cloud. The hub is linked to the Cloud via an access modem using Ethernet or Wi-Fi connectivity. The ninja block (our model of an IoT gateway) contains a BeagleBone Black Linux micro-computer coupled with a customized daughter board known as an Arduino cape. Our measurements indicate that the block consumes about 2.2 W when connected to the Ethernet port of a CPE modem.

#### B. Wi-Fi Access Network

We consider two types of Wi-Fi models: a home Wi-Fi model, typical of a home network with a single user (or few users), and a shared Wi-Fi model typical of a corporate or industrial setting with many users. The shared device model, (5), is employed for the shared Wi-Fi scenario and the unshared device model, (2), for the home scenario. We used a TRENDnet N300 [15] with a power rating of 3 W, as a representative home Wi-Fi router. The Enterasys AP3660 [16] with a power consumption of 21 W is used as a shared Wi-Fi access point (AP). We use the power rating for home Wi-Fi as reported because it represents a single user in our model. For shared Wi-Fi access, we apply (4) to determine the ‘‘per-bit’’ energy consumption of the AP whilst considering a maximum bitrate of 150 Mb/s and percentage utilization ( $R$ ) of 20% ( $C_{bgd} = 30$  Mb/s, hence  $C_{bgd} \gg \gg C_{IoT}$ ). The energy-per-bit for shared Wi-Fi AP  $E_{BIT}^{AP}$  is thus calculated as 433 nJ/bit.

TABLE I. POWER CONSUMPTION, DATA RATE AND ENERGY PER BIT VALUES FOR NETWORK ELEMENTS

Network Element	Device Model	Max DS Capacity (Gb/s)	Max US Capacity (Gb/s)	Number of Ports/Users	Max Power Consumption (W)	Energy per bit (nJ/bit)
IoT Gateway	Ninja Block v2	0.1	0.1	1	2.2	-
VDSL2 Modem (CPE)	Eltek V7600 A1	0.1	0.1	1	7	-
Home Wi-Fi Router (CPE)	TRENDnet N300	0.3	0.3	1	3	-
LTE Wireless Modem (CPE)	ZTE MF 823	0.04	0.01	1	1.4	-
Optical Network Terminal (CPE)	Zhone GPON 2301	2.4	1.2	1	5	-
Ethernet Media Converter (CPE)	CTC Union FTH4-1000MS	1	1	1	4	-
Multi-Service Access Node	ZyXel IES-5106	12	12	120	391	-
Shared Wi-Fi Access Point	Enterasys AP3660	0.3	0.3	256	21	433
Ethernet Switch	Cisco 3800X-24FS	24	24	24	238	37
Optical Line Terminal	Tellabs 1134	38.4	19.2	512	480	173
LTE Base Station	EARTH 2012 Model	0.0734	0.0206	-	528	-

### C. VDSL2 Access Network

For a VDSL2 node, we have used a fully-loaded ZyXel IES-5106 MSAN [17] which consumes 391 W. Since the number of user connections is fixed, the power per IoT gateway for the shared remote node is given as:  $P_{RN}^{vds} = P_{max} / N_{max}$ . This is thus calculated as 3.3 W. The CPE modem for VDSL2 is an Eltek V7600 A1 [18] modem and consumes 7 W.

### D. Point-to-Point Optical Network Access (PtP)

A PtP installation has no remote node ( $P_{RN} = 0$ ). To model a PtP optical network, we used a Cisco ME 3800X-24FS [19] Ethernet switch as our Edge node. The 3800X consumes 238 W on full-load. As the 3800X is a shared network device, we assume 20% capacity utilization, resulting in a background uplink and downlink traffic ( $C_{bgd} = 2.4$  Gb/s) that is far greater than our IoT test throughput range ( $0 \leq B \leq 1$  Mb/s). Hence we used (4) to calculate the energy-per-bit of the Ethernet switch, calculated as 37 nJ/bit. The CTC Union FTH4-1000MS [20] Gigabit Ethernet (GbE) media converter is used as the PtP CPE modem with a power consumption of 4 W.

### E. Passive Optical Network Access (PON)

In modelling PON, we consider a GPON installed network with a 32-way split ratio. At the remote node a single fiber is passively split to serve up to 32 Optical Network Terminal (ONT) (28 ONTs in practice). Tellabs' 1134 [21] OLT is used as the edge node, having a full configuration power consumption of 480 W. As the optical line terminal is heavily shared between many services and users, the power per IoT gateway is calculated using (4) and (5). Assuming an average utilization of 20%, the energy-per-bit of the 1134 OLT is calculated as 173 nJ/bit. Our chosen ONT is Zhone's ZNID-2301 [22] with a power consumption of 5 W.

### F. LTE Network

Using the 2012 reference Base Station (BS) put forth by the Earth Project [23], we consider an LTE Rel-8 Macrocell BS, with 10 MHz bandwidth and frequency division duplexing as the LTE remote node. The Rel-8 BS has a 2x2 MIMO configuration with 2 transceivers per sector. A single LTE BS can maintain hundreds or thousands of active users or gateway devices at any given time and is hence considered as shared network equipment. We use the ZTE MF823 LTE wireless modem as our 4G CPE modem, with a measured power consumption of 1.4 W when active. For the BS, we assume that the power consumption grows proportionally with the number

of transceivers. The total power consumption of a BS [23] with  $N$  transceivers is given as:

$$P_{BS} = N \times \frac{P_{PA} + P_{RF} + P_{BB}}{(1 - \sigma_{DC})(1 - \sigma_{MS})(1 - \sigma_{cool})} \quad (6)$$

where  $P_{PA}$ ,  $P_{RF}$  and  $P_{BB}$  account for the power draw by the power amplifier (PA), the RF transceiver module and baseband unit,  $\sigma_{DC}$ ,  $\sigma_{MS}$ ,  $\sigma_{cool}$  account for the loss factors due to the DC-DC power supply, main supply and cooling overheads (see table 2) respectively. The radio frequency and signal processing components of a BS include a number of functions common to both transmitter and receiver subsystems, for which we split the power consumption equally, except where the data for each of the subsystems is available separately. The PA in the BS however is used only in the transmitter, and its consumption is fully assigned to the downlink energy usage. The transmitter PA power consumption is treated as load-proportional in accordance with [23], whilst the consumption of the remaining components is considered to be independent of load.

TABLE II. POWER VALUES FOR LTE BASE STATION COMPONENTS

BS Component	Single Radio
RF Chain (TX / RX)	5.7 / 5.1 W
Baseband Unit	14.8 W
PA Power (Idle / Max)	38.8 / 102.6 W
Main Supply Loss ( $\sigma_{MS}$ )	7%
Cooling Loss ( $\sigma_{cool}$ )	9%
DC-DC Loss ( $\sigma_{DC}$ )	6%

Consider a single sector of the 2012 reference BS with two transceivers per sector ( $N = 2$ ). Using (6), we calculate the power consumption of the transmit section (downlink) as 130 W and 291 W in the idle and full-load states respectively. For the receiver section (uplink) of the BS, there is no PA (hence  $P_{PA} = 0$ ). The power consumed by the receiver of the BS, is thus considerably lower than that of the BS transmitter, hence the incentive for modelling the transmitter and receiver separately. This we calculate as 31 W.

The expressions for the uplink ( $P_{RN(U)}$ ) and downlink ( $P_{RN(D)}$ ) power per IoT gateway for an LTE BS is given in (7) and (8).  $P_{idle}$  and  $P_{max}$  are the no load and maximum load power in each case.  $C_{IoT}$  is the data rate from an IoT gateway (with a 5:1 uplink to downlink ratio).  $C_{max}$  and  $C_{ave}$  are the maximum and average sector data rate and  $C_{bgd}$  the background traffic of

the cell sector as a function of hourly utilization  $U$  (where  $C_{bgd} = UC_{ave}$ ) for both uplink and downlink traffic. For the uplink power calculation, the incremental energy consumption is neglected due to the absence of a PA in the uplink chain.

$$P_{RN(U)} = \frac{P_{idle} \times C_{IoT(U)}}{C_{bgd(U)} + C_{IoT(U)}} \quad (7)$$

$$P_{RN(D)} = \frac{P_{idle} \times C_{IoT(D)}}{C_{bgd(D)} + C_{IoT(D)}} + \frac{P_{max} - P_{idle}}{C_{max}} C_{IoT(D)} \quad (8)$$

Lastly, we require an estimate of the BS sector's uplink and downlink background traffic. A useful approximation to the mobile network diurnal traffic profile, based on data obtained from a telecoms operator, is given in [24] (see Fig. 3). For a dense urban area, this shows the traffic profile varies from 20% of daily average traffic level during the early hours of a day to 140% of average during busy-hours. From [11] the average achievable downlink and uplink data rates of a 10 MHz 2x2 LTE BS sector are taken as 12 Mb/s and 6 Mb/s whilst the peak data rates are 73.4 Mb/s and 20.6 Mb/s respectively.

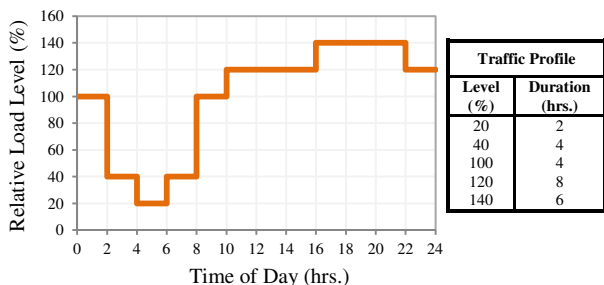

Fig. 3: Daily Traffic Profile of a Dense Urban area

Using the diurnal traffic utilization values shown in Fig. 3, the average data rates and the expressions for power given in (7) and (8), we calculated the share of the total base station power attributable to an IoT user accessing a BS remote node, for throughputs between 1 kb/s and 1 Mb/s:  $P_{RN} = \sum (P_{RN(U)} + P_{RN(D)})$ . Figure 4 shows the power consumption for the five different traffic utilization profiles of a typical weekday. As depicted in Fig.1, the BS connects to the core of the network via an Ethernet switch (Cisco 3800X).

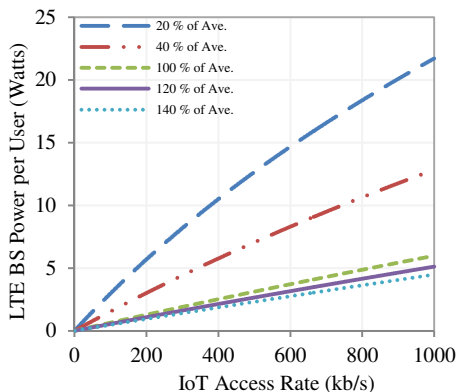

Fig. 4: LTE sector power consumption as a function of IoT Access rate for different background traffic profiles

## VI. RESULTS

In this work, we calculate the power consumption of different access technologies using information from network element datasheets and measurements where applicable. The power consumption of each network element involved in the transport of IoT data is summed in accordance with (1). The graph in Fig.5 depicts the relative power usage of the different network architectures for data access rates between 1 kb/s and 1 Mb/s at the IoT gateway. Our results indicate that the power usage of the fixed access network technologies is largely dominated by the power consumed by their respective CPE modems. PON access is the most power efficient of the wired technologies by virtue of its passive remote node and effective bandwidth sharing regime. The dedicated 1 Gb/s bandwidth of PtP FTTP has little significance as IoT traffic may require significantly lower bandwidth. VDSL2, which uses FTTC or FTTB deployments, is seen as the least power efficient for sub-1 Mb/s data access rates. This is attributed to the presence of an active power consuming network element at the remote node and the VDSL2 modem (which mostly includes Wi-Fi).

For LTE wireless technology, we see that the algorithm for power sharing between IoT and background traffic leads to a time-of-day dependence of power consumption as depicted in Fig. 4. Due to the high volume of traffic during busy-hours between 4pm and 10pm (140% of average), the power share for LTE access is low, but increases greatly after midnight between 2am and 4am (20% of average) as the volume of traffic drops. For IoT services using LTE access, we show the power consumption apportioned to IoT traffic for the low, medium and high background traffic volume in Fig. 5. The power consumption of LTE below 10 kb/s is relatively independent of traffic level but increases rapidly above 10 kb/s.

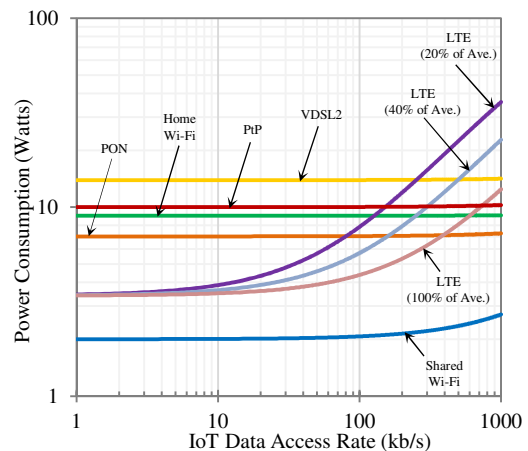

Fig. 5: Power consumption per IoT gateway for different access network technologies

The low and medium background utilization traffic curves show that LTE becomes the least power-efficient access technology beyond about 250 kb/s and 500 kb/s respectively, whilst for the high background traffic utilization scenario, LTE consumption is only just below that of the VDSL2 access at a 1 Mb/s IoT traffic level. This seems to show LTE wireless as power-efficient in the IoT scenario, in contrast to downlink focused studies (e.g. [4]). The difference between home Wi-Fi deployment with a handful of users, and shared Wi-Fi with

many users is substantial. Although a shared Wi-Fi deployment may operate at higher access rates and consume more power, the sharing strategy ensures a very small per-gateway or per user footprint. The curve for shared Wi-Fi in Fig. 5 also indicates gradual increment in power as the IoT user access rate grows beyond 100 kb/s. The graph in Fig. 6 shows total energy efficiency of the different access technologies considering sub-1 Mb/s IoT data access rates. Generally, energy efficiency tends to scale linearly with increase in data throughput. Hence a network node is perceived to be less energy-efficient at lower data access rates. From Fig. 6, the energy-per-bit decreases sharply for all access technologies with increase in data access rate, although VDSL2 remains the least energy efficient up to about 250 kb/s and 500 kb/s, above which LTE becomes the least efficient. Shared Wi-Fi access has the lowest energy-per-bit value at 2.7  $\mu$ J/bit for a data access rate of 1 Mb/s.

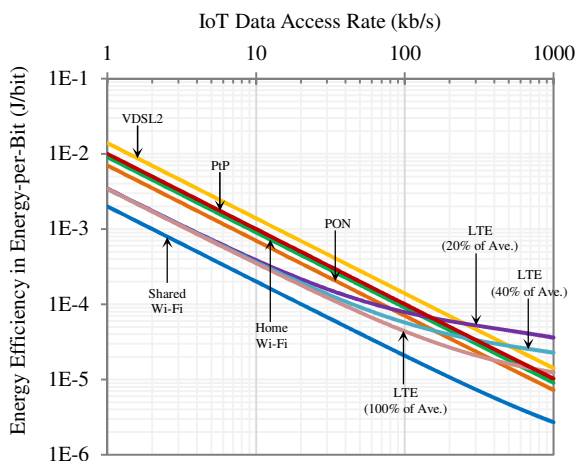

Fig. 6: Energy efficiency of different IoT access network technologies

## VII. CONCLUSION

In this study, we have developed a power consumption model for estimating the power consumption per IoT gateway for sub-1 Mb/s data access rates. Our results indicate that VDSL2 is the least power efficient for most of the assessed data throughput range, while LTE becomes least efficient above 250 kb/s or 500 kb/s depending on the traffic volume and time of day. PON is evidently the most power efficient fixed access network technology while shared Wi-Fi access with PON backbone is the overall most power efficient wireless access technology provided that the shared Wi-Fi also carries a modest level of background traffic. LTE energy usage is low at low traffic levels but increases rapidly as the share of total traffic allocated to the IoT becomes significant compared with the cell background traffic. Whilst we have shown here the inefficiencies of some network architectures relative to others, the choice of an IoT access technology will ultimately depend on the type of application, the rate of data generation and the cost of deployment. Wireless access has a significant advantage of being ubiquitous today and easy to augment once deployed; hence shared Wi-Fi may be a good choice as it satisfies the need for mobility and flexibility whilst being energy-efficient.

## REFERENCES

- [1] D. Evans, "The internet of things: how the next evolution of the internet is changing everything," *CISCO white paper*, vol. 1, 2011.
- [2] Nordic nRF51822 [Online]. Available: <https://www.nordicsemi.com/eng/Products/Bluetooth-Smart-Bluetooth-low-energy/nRF51822>
- [3] I. Strategy and P. Unit, "ITU Internet Reports 2005: The internet of things," *Geneva: International Telecommunication Union (ITU)*, 2005.
- [4] J. Baliga, R. Ayre, K. Hinton, and R. S. Tucker, "Energy consumption in wired and wireless access networks," *Communications Magazine, IEEE*, vol. 49, pp. 70-77, 2011.
- [5] W. Vereecken, W. Van Heddeghem, M. Deruyck, B. Puype, B. Lannoo, W. Joseph, D. Colle, L. Martens, and P. Demeester, "Power consumption in telecommunication networks: overview and reduction strategies," *Communications Magazine, IEEE*, vol. 49, pp. 62-69, 2011.
- [6] K. Hinton, J. Baliga, M. Z. Feng, R. Ayre, and R. Tucker, "Power consumption and energy efficiency in the internet," *Network, IEEE*, vol. 25, pp. 6-12, 2011.
- [7] C. Lange and A. Gladisch, "On the energy consumption of FTTH access networks," in *Optical fiber communication conference*, 2009, p. JThA79.
- [8] S. Aleksić and A. Lovrić, "Power consumption of wired access network technologies," in *Communication Systems Networks and Digital Signal Processing (CSNDSP), 2010 7th International Symposium on*, 2010, pp. 147-151.
- [9] L. Atzori, A. Iera, and G. Morabito, "The internet of things: A survey," *Computer networks*, vol. 54, pp. 2787-2805, 2010.
- [10] V. Oksman, H. Schenk, A. Clausen, J. M. Cioffi, M. Mohseni, G. Ginis, C. Nuzman, J. Maes, M. Peeters, and K. D. Fisher, "The ITU-T's new g-vector standard proliferates 100 mb/s dsl," *IEEE Communications Magazine*, vol. 48, pp. 140-148, 2010.
- [11] D. Fritz, "The Evolving Wireless World - Alcatel Lucent Presentation," Aug 2011. Available: [www.opastco.org/doclibrary/2105/Fritz.pdf](http://www.opastco.org/doclibrary/2105/Fritz.pdf)
- [12] P. Mahadevan, P. Sharma, S. Banerjee, and P. Ranganathan, "A power benchmarking framework for network devices," in *NETWORKING 2009*, ed: Springer, 2009, pp. 795-808.
- [13] A. Vishwanath, F. Jalali, R. Ayre, T. Alpcan, K. Hinton, and R. S. Tucker, "Energy consumption of interactive cloud-based document processing applications," in *Communications (ICC), 2013 IEEE International Conference on*, 2013, pp. 4212-4216.
- [14] Ninja Blocks [Online]. Available: [www.ninjablocks.com](http://www.ninjablocks.com)
- [15] TRENDnet N300 Wireless Home Router [Online]. Available: [http://www.trendnet.com/products/proddetail.asp?prod=230\\_TEW-731BR](http://www.trendnet.com/products/proddetail.asp?prod=230_TEW-731BR)
- [16] Enterasys AP3660 Wireless Access Point [Online]. Available: <http://www.netsolutionstore.com/AP3660.asp>
- [17] Zyxel IES-5106 Series [Online]. Available: <http://www.zyxel.com>
- [18] Eltek Technologies (Eltek V7601-A1) [Online]. Available: [http://www.eltektec.com/images/Datasheets/vdsl/Eltek\\_V7601-A1\\_datasheet.pdf](http://www.eltektec.com/images/Datasheets/vdsl/Eltek_V7601-A1_datasheet.pdf)
- [19] Cisco, "Cisco ME 3800X Series Ethernet Switch Router," 2013. Available: [http://www.cisco.com/c/en/us/products/collateral/switches/me-3800x-series-carrier-ethernet-switch-routers/data\\_sheet\\_c78-601950.pdf](http://www.cisco.com/c/en/us/products/collateral/switches/me-3800x-series-carrier-ethernet-switch-routers/data_sheet_c78-601950.pdf)
- [20] CTCUnion, "Web Smart GbE OAM/IP Managed Converter FTH4-1000MS," 2014. Available: <http://www.ctcu.com.tw/download/catalog/2014/3-12-FTH4-1000MS.pdf>
- [21] Tellabs 1100 Series OLT [Online]. Available: <http://www.tellabs.com/products/tellabs1100olt.shtml>
- [22] Zhone, "zNID - Indoor GPON ONT," 2013. Available: <http://www.zhone.com/products/ZNID-GPON-2301/ZNID-GPON-2301.pdf>
- [23] G. Auer, O. Blume, V. Giannini, I. Godor, M. Imran, Y. Jading, E. Katranaras, M. Olsson, D. Sabella, and P. Skillermark, "D2. 3: Energy efficiency analysis of the reference systems, areas of improvements and target breakdown," *INFOICT-247733 EARTH (Energy Aware Radio and Network Technologies), Tech. Rep.*, 2010.
- [24] O. Blume, A. Ambrosy, M. Wilhelm, and U. Barth, "Energy Efficiency of LTE networks under traffic loads of 2020," in *Wireless Communication Systems (ISWCS 2013), Proceedings of the Tenth International Symposium on*, 2013, pp. 1-5.